

BUTTERFLY VALVE TYPE F 012-DE



Butterfly valve type F 012-DE with worm gear and handwheel.

TECHNICAL DATA

Nominal diameter:	DN 200 - DN 1400
Face-to-face:	EN 558-1-GR14
Flange accommodation:	EN 1092-2 PN 10/16
Top flange:	EN ISO 5211
Marking:	EN 19
Design standard:	EN 593
Temperature range:	Up to + 50°C
Corrosion protection:	EKB >250/300 µm, RAL 5015, sky blue Option: inside enameled, cobalt blue

FEATURES

- Soft seated, double eccentric butterfly valve
- Tight sealing in both flow directions. One side flanging is possible
- Suitable for subsurface installation
- The sealing can be adjusted or replaced without dismantling the disc
- Shafts are capsuled. No media contact
- DIN DVGW certified

GENERAL APPLICATIONS

- Water and wastewater technology
- Potable water
- Wastewater, TS max. 3%
- Not applicable with long-fibred media

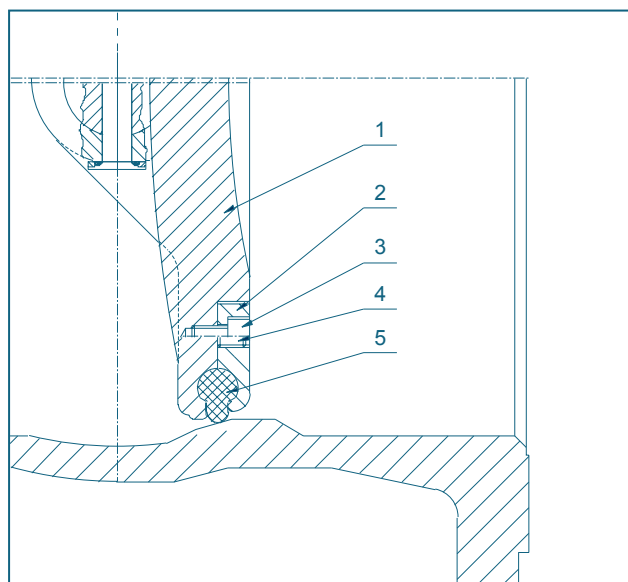

- 1 = Disc
2 = Pressure ring
3 = Fastening screw
4 = Counter set screw
5 = Elastomer seat

BUTTERFLY VALVE TYPE F 012-DE

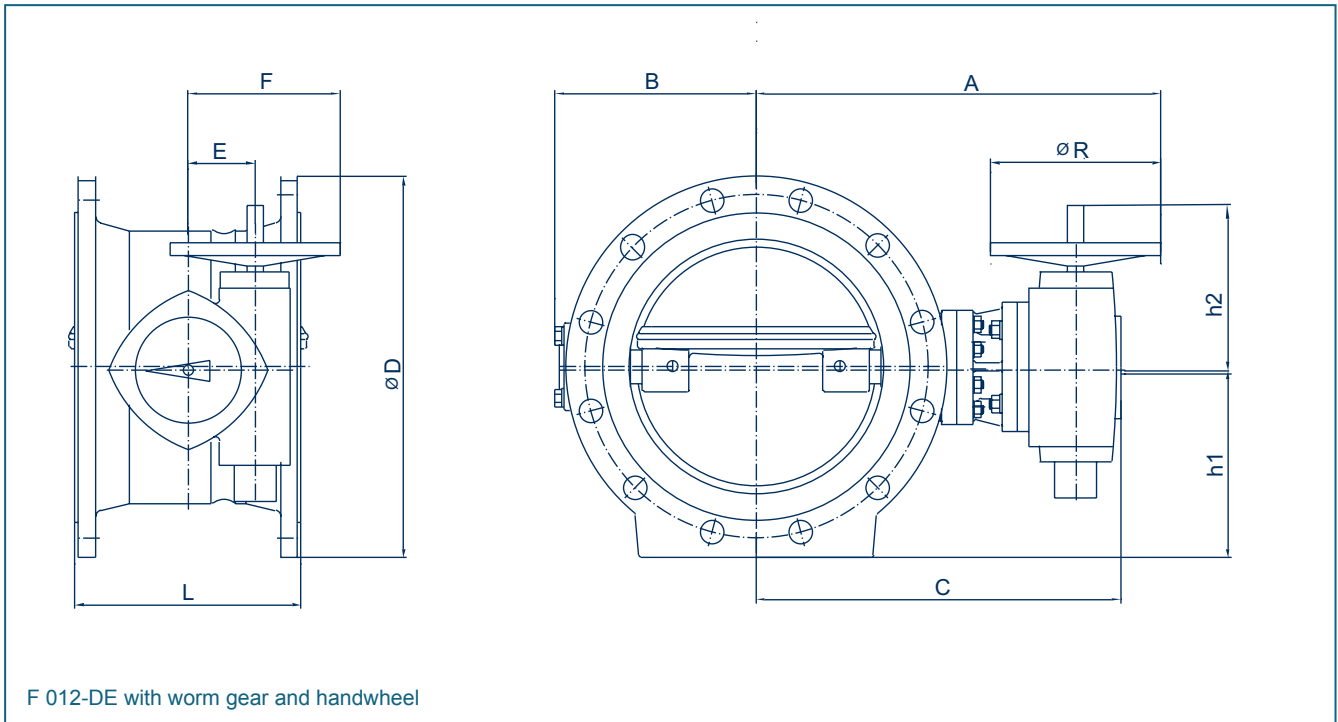

PN 10

DN [mm]	Size [in]	Dimensions [mm]										Weight [kg]
		A	B	C	ØD	E	F	h1	h2	L	ØR	
200	8	380	180	320	340	50	150	170	145	230	200	55
250	10	445	210	378	400	63	190	200	183	250	250	95
300	12	520	235	425	455	80	240	230	186	270	315	125
350	14	545	270	453	505	80	240	255	186	290	315	145
400	16	655	295	538	565	100	300	285	319	310	400	195
500	20	715	365	599	670	100	300	335	319	350	400	265
600	24	780	425	668	780	125	325	390	327	390	400	360
700	28	787	510	687	895	160	360	450	400	430	400	585
800	32	840	560	737	1015	160	360	510	400	470	400	738
900	36	904	628	804	1115	160	360	560	400	510	400	995
1000	40	1090	680	990	1230	160	360	620	400	550	400	1285
1200	48	1305	825	1225	1455	200	450	730	505	630	400	2120
1400	56	1355	965	1225	1675	250	500	840	600	710	500	2850

PN 16

DN [mm]	Size [in]	Dimensions [mm]										Weight [kg]
		A	B	C	ØD	E	F	h1	h2	L	ØR	
200	8	380	180	320	340	50	150	170	145	230	200	55
250	10	445	210	378	400	63	190	200	183	250	250	95
300	12	520	235	425	455	80	240	230	186	270	315	125
350	14	545	270	453	520	80	240	260	186	290	315	150
400	16	655	295	538	580	100	300	290	319	310	400	200
450	18	690	340	568	640	100	300	318	319	330	400	235
500	20	735	380	623	715	125	325	360	327	350	400	310
600	24	768	474	667	840	160	360	420	400	390	400	480

Bigger sizes and higher operating pressure upon request.

Subject to change without notice

BUTTERFLY VALVE TYPE F 012-DE

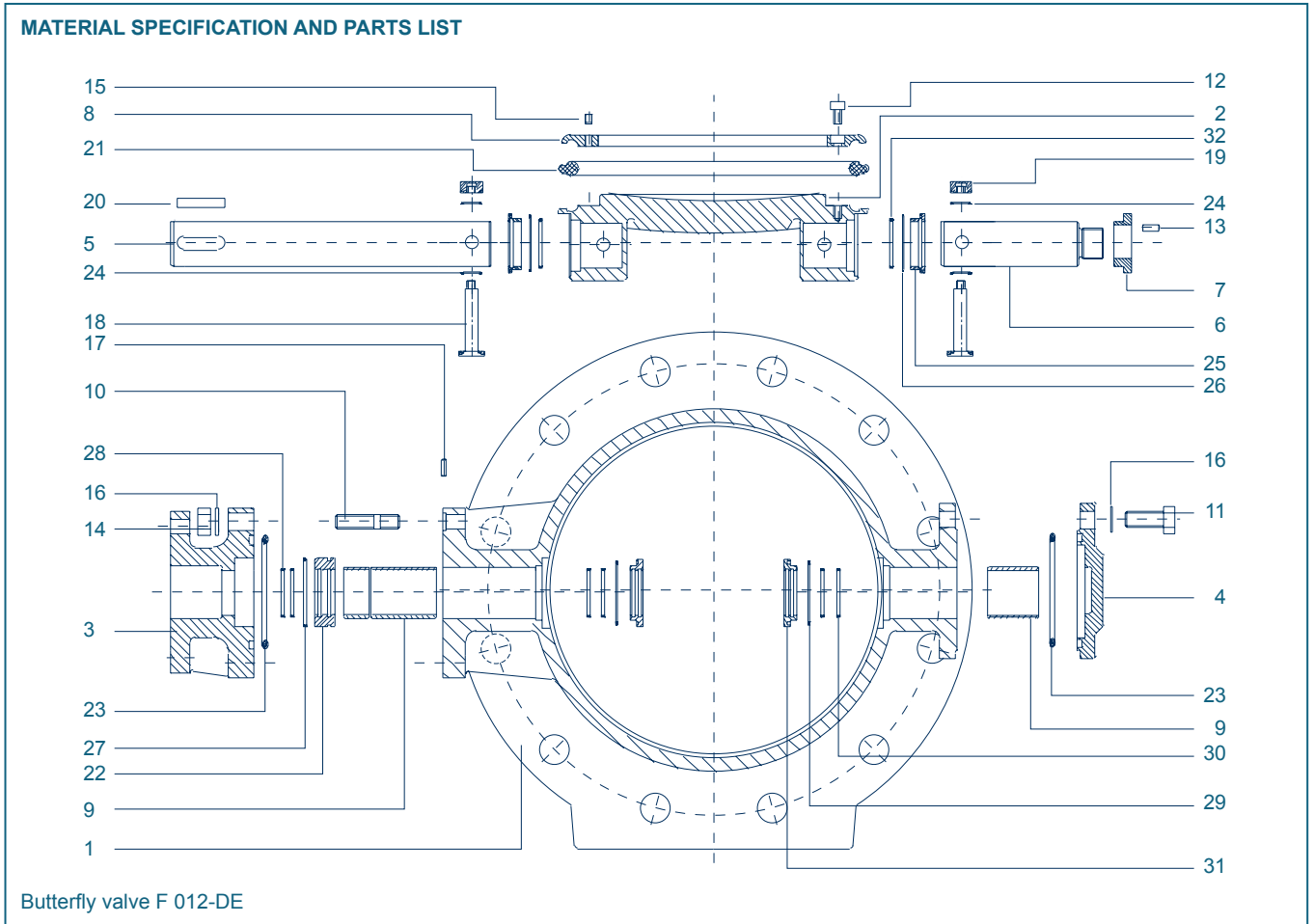

Pos.	Description	Material	Material-No.	Pos.	Description	Material	Material-No.
1	Body	GGG	EN-JS 1030	15	Set screw	St. Steel	A2-70
2	Flap	GGG	EN-JS 1030	16	Disc	St. Steel	1.4301
3	Connection flange	GGG	EN-JS 1030	17	Grooved stud	St. Steel	A2-70
4	Cover plate	GGG	EN-JS 1030	18	Threaded pin	St. Steel	A2-70
5	Driveshaft	St. Steel	1.4021	19	Threaded pin - screw nut	St. Steel	A2-70
		St. Steel	1.4122	20	Fitting key	Steel	1.0037
		Duplex	1.4462	21	Seal ring		EPDM/ NBR
6	Shaft	St. Steel	1.4021	22	Holding ring	Brass	2.0402
		St. Steel	1.4122	23	O-ring		EPDM/ NBR
		Duplex	1.4462	24	O-ring		EPDM/ NBR
7	Checking nut	St. Steel	1.4021	25*	Sealing bush	Brass	2.0402
8	Clamping ring	St. Steel	1.4301	26*	O-ring		EPDM/ NBR
		St. Steel	1.4571	27	O-ring		EPDM/ NBR
9	Bearing sleeve	Du	PTFE/ Bronze	28	O-ring		EPDM/ NBR
10	Stud bolt	St. Steel	A2-70	29*	O-ring		EPDM/ NBR
11	Hex bolt	St. Steel	A2-70	30*	O-ring		EPDM/ NBR
12	Pan screw	St. Steel	A2-70	31*	Sealing bush	Brass	2.0402
13	Pan screw	St. Steel	A2-70	32*	O-ring		EPDM/ NBR
14	Pan screw	St. Steel	A2-70				

* These parts are replaced by a profile ring at DN 200 and DN 250.
Other materials upon request.

Subject to change without notice

BUTTERFLY VALVE TYPE F 012-DE

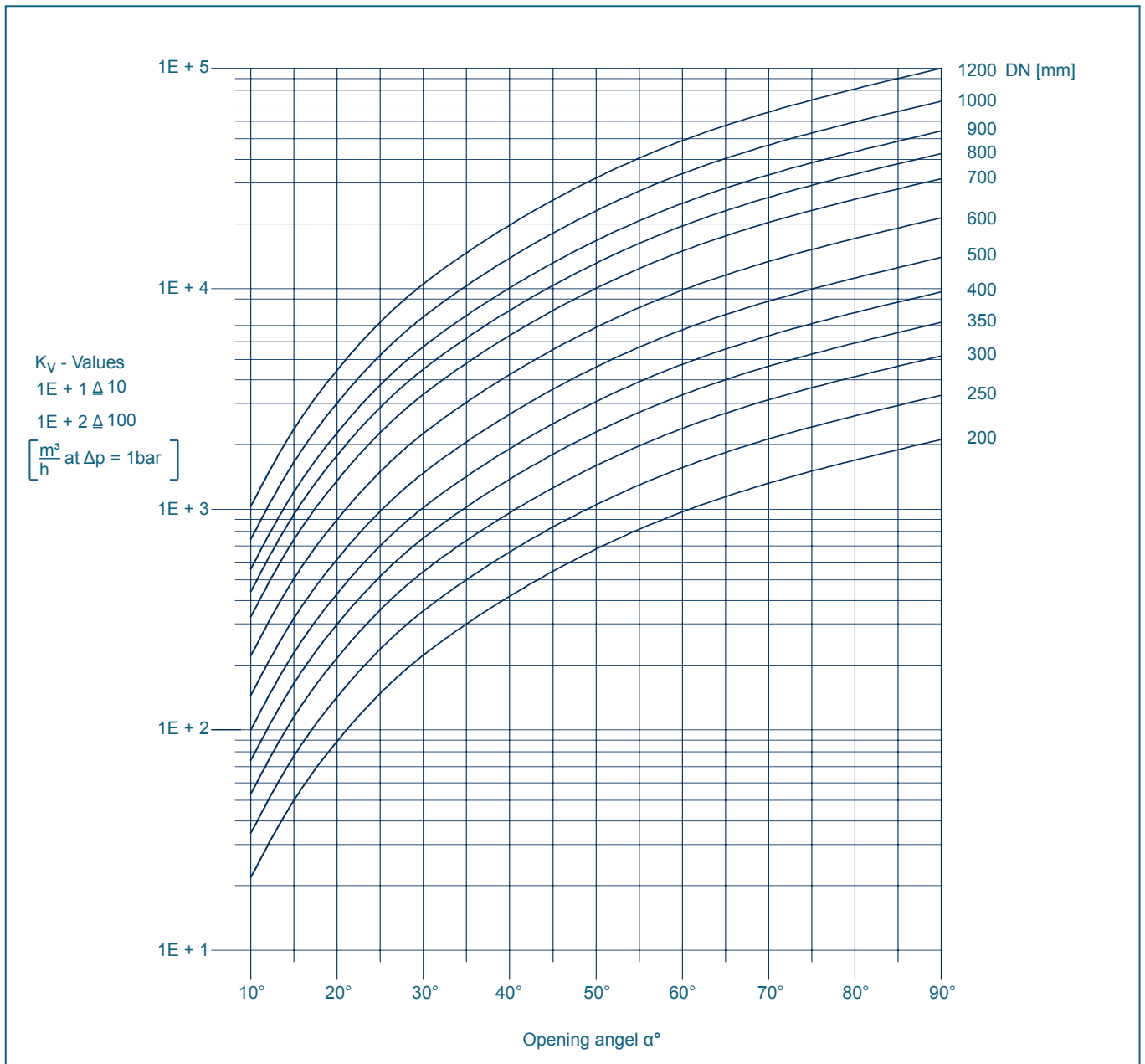

The valve series F 012-DE are mainly used for on/ off operations. They can be used as a control valve conditionally. The differential pressure to be regulated is between 1 to 3 bar (depending on size).

INSPECTION AND ACCEPTANCE

DN [mm]	Flange [DIN EN 1092-2]	Testpressure [bar]		Operating pressure [bar]
		Body	Closing-off	
200-1400	PN 10	16	11,0	10
200-1400	PN 16	24	17,6	16

The inspection is conducted according to DIN EN 12266-1; DIN EN 1074-1/2 with water or air allowing leakage rate A. Valves used with gas be tested according to DIN 3230/5 and on customer request in testing groups PG1, PG2 or PG3.